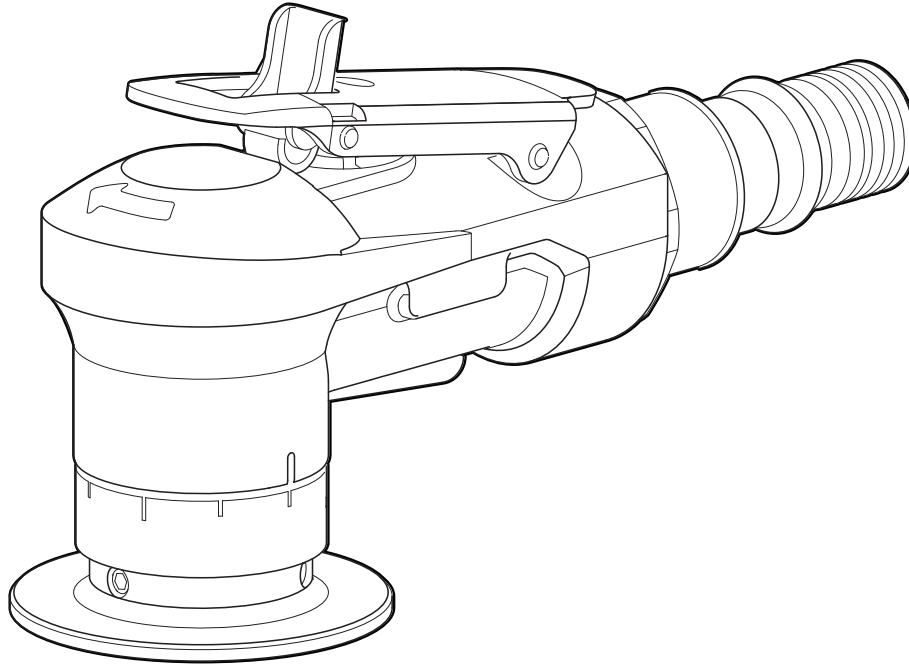

INSTRUCTION MANUAL

CIRCUIT BEVELER

Model: CB-01

[Specifications]

Model		CB-01
Maximum operating pressure	MPa	0.6
Air consumption (No load)	m ³ /min	0.15
Rated speed (No load)	min ⁻¹	28000
Mass (weight)	kg	0.5
Sound pressure level *1	dB(A)	88
Sound power level *1	dB(A)	99
Vibration level [Uncertainty K] *2	m/s ²	≤ 2.5 (1.8 [0.67])
Chamfering capacity		Mild steel: 0 to C1 Stainless steel: 0 to C0.5 Aluminum: 0 to C1
Chamfer angle		45°
Minimum workpiece thickness	mm	1.5 (C0.5)
Thread size of Air Inlet		Rc 1/4

*1 Based on the ISO 15744 measurement standard.

*2 Based on the ISO 20643 measurement standard for the 3-axis composite value of frequency-weighted acceleration effective values in hand-held tools.

- Please read manual carefully before you attempt to use your tool so that you may use it properly and safely.
- Keep the manual handy – so you can use it whenever necessary.

- Due to continuous product development/improvement, the specifications and configurations in this document are subject to change without prior notice.

Instructions

Thank you very much for your purchase of this NITTO KOHKI product.
Before using your tool, please read this manual carefully so that you may use it properly to get the most out of it.
Please keep the manual handy - so you can use it whenever necessary.

The following Safety notations are used throughout the manual to highlight safety precautions for the user and for the tool.



WARNING:

Indicates a potentially hazardous situation which, if not avoided by following the instructions given, could result in death or serious injury.



CAUTION:

Indicates a potentially hazardous situation which, if not avoided by following the instructions given, could result in injury or material damage.

* Please note, however, that failure to observe safety precautions under the “ **CAUTION**” category could result in a serious occurrence depending on the situation.

Please observe all safety precautions in the manual.

CAUTION: Important precautions for tool setup, operation and maintenance.

About pictograms



WARNING:

Failure to follow the instructions for handling could cause danger when using the tool.



Using this tool improperly could result in serious injury. Read the instruction manual before using.



Always wear suitable eye protection.



Always wear suitable hearing protection.



Always wear respiratory protective equipment (PPE).

Contents

Precautions on Use (Make sure to follow the instructions given)	1	Replacing the Indexable Inserts.....	9
General Power Tool Safety Warnings	1	Adjusting the rotation speed	10
General Pneumatic Tool Safety Warnings	4	Chamfering	10
Product Specific Safety Rules.....	4	Replacing the Guide Bearing.....	11
1 Application	5	6 Maintenance and Inspection.....	12
2 Checking Inside the Package	5	Storing the tool.....	12
3 Part Names.....	5	Maintaining the tool.....	12
4 Air Supply	6	Maintaining the Guide Plate.....	12
5 How to Use	7	Ordering parts	13
Dimensions of material that can be chamfered.....	7	Disposal	13
Start and stop.....	8	7 Separately-sold Products	13
Adjusting the chamfering amount	8		
Feed rate.....	9		

California Proposition 65

⚠ WARNING

Some dust created by power sanding, sawing, grinding, drilling, and other construction activities contains chemicals known [to the State of California] to cause cancer birth defects or other reproductive harm. Some examples of these chemicals are:

- Lead from lead-based paints,
- Crystalline silica from bricks and cement and other masonry products, and
- Arsenic and chromium from chemically-treated lumber.

Your risk from these exposures varies, depending on how often you do this type of work. To reduce your exposure to these chemicals: work in a well ventilated area, and work with approved safety equipment, such as those dust masks that are specially designed to filter out microscopic particles.

Precautions on Use (Make sure to follow the instructions given)

Before using your tool, to avoid personal injury always take the basic precautions explained in later sections.

General Power Tool Safety Warnings

Personal safety

⚠ WARNING

- **Dress properly.**

Do not wear loose clothing or jewelry which may be entangled in moving parts. Wear a pair of non-slip shoes. If your hair is long, wear a protective cap that fully contains your hair.

- **Always wear protective eyewear.**

Corrective glasses are not considered to be protective eyewear. Always wear appropriate eye protection.

- **Wear a dust mask.**

When dust is generated in the workplace, wear a dust mask.

- **Use a dust collector or dust collection equipment correctly.**

If a dust collector or dust collection equipment is available, check that it is connected and used properly. Use of a dust collector can reduce risk caused by dust.

- **When loud noise is generated in the workplace, wear a hearing protection.**

- **Do not overreach.**

Use a suitable support structure and maintain proper footing and balance at all times.

- **Be on your guard when working.**

Do not use the tool when you are tired.

When using the tool, take due care about the method of handling and working and pay sufficient attention to the surrounding environment.

- **Never touch the tip of moving parts when the tool is running.**

Also, do not direct the tip of moving parts toward people or animals.

- **Be aware of tool vibration and recoil. Some tools can cause a considerable amount of vibration.**

Depending on the type of work, the tool settings, and the length of operation, the tool could place a tremendous burden on your hands, arms and body.

The tool may cause a vibration injury or tendonitis. Avoid long-term use and take appropriate breaks.

Consult a doctor if you experience any discomfort or pain while operating the tool.

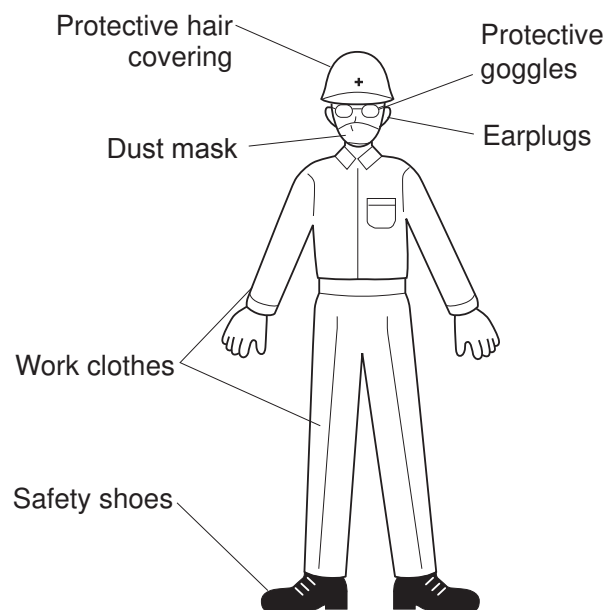

Work area safety

⚠ WARNING

- **Do not use the tool at home.**
This is a professional tool (industrial or work tool for business). Do not bring the tool home and use it there.
- **Keep the work area clean.**
Working in a messy work area or work table could cause an accident.
- **Be cautious about the work area.**
Do not expose the tool to rain.
Do not use the tool in a damp or wet place.
Keep the work area well lit.
- **Do not operate the tool in an explosive atmosphere, such as in the presence of flammable liquids (thinner, lacquer, gasoline, etc.) or gas.**
- **Do not let children come close to the work area.**
Keep children and bystanders away while operating tool.
- **Some tools generate loud noise.**
Check that the noise regulations in the current location are complied with.
- **When work has to be done in high locations, make sure there is nobody underneath the work area.**
Dropping the tool or material could cause an accident or injury.
- **Before starting operation, make sure that there is no conduit, water pipe or gas pipe buried near the work area.**
If the tool touches a buried object, it could cause electrical shock, electrical leakage, or a gas leak, which could result in an accident.

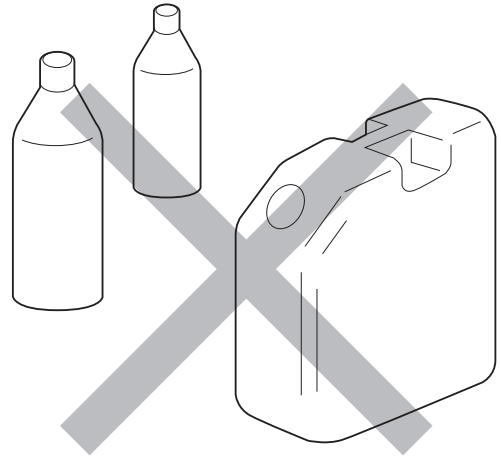

Before starting work

⚠ WARNING

- **Perform inspection before using the tool.**
Before using the tool, check for loose screws and for damage to the protective cover or other parts. Make sure that the tool operates normally and functions as intended.
Check that there are no problems with the positional adjustment and tightening of moving parts, damage to parts, attachment of parts, and all other positions that could affect operation.
For parts replacement and repair, follow the instructions indicated in the instruction manual.
If there are no instructions in the instruction manual, contact the retailer where you purchased the tool or the nearest NITTO service member store.
Do not use the power tool if the operation switch does not turn it ON and OFF.
- **Securely mount the tip tools.**
An incorrectly mounted tip tool may fly out and cause damage or injury.
- **After adjustment, be sure to remove tools such as spanners, wrenches, etc.**
- **Use appropriate tools.**
Do not force small tools to do the job of a heavy duty tool. Do not use tools for purposes not intended.
- **Do not use tools in an unreasonable manner.**
When the specifications are followed, tools can be used efficiently and safely.
- **Secure workpieces.**
Where possible use clamps or a vise to hold the work. This is safer than holding the workpiece by hand and keeps both hands free for working.

Handling tools

WARNING

- **Storing the tool**

When the tool is not used, store the tool in a dry location. Also, store the tool out of the reach of children. For some tools, the storage temperature and humidity are specified. Store the tool in an appropriate location.

- **Be cautious about how the tool is carried.**

Do not carry the tool with your hand touching the operation switch.

- **Do not leave the tool while the tool is still running.**

Do not leave the work area until you turn off the operation switch, disconnect the power source, and the tool has completely stopped.

- **Do not allow the following chemicals to come into contact with the tool, as parts could deteriorate.**

Acetone, benzene, thinner, ketone, ether, trichloroethylene and other similar chemicals

Maintenance and Inspection

WARNING

- **Do not disassemble or modify the tool.**

Using the tool after disassembling or modification could cause an accident or injury.

- **Inspect tip tools and accessories.**

Always inspect tip tools and accessories for damage or deterioration before attaching them to the tool.

If damage or deterioration is found, request repair from the retailer where you purchased the tool or the nearest NITTO service member store.

- **Inspect for damage.**

Carefully check for damage to accessories or other parts. Check that the tool operates normally and functions appropriately.

If accessories or parts have been damaged or could hinder work, request repair from the retailer where you purchased the tool or the nearest NITTO service member store.

- **Request repair from a dedicated store.**

For repair or replacement of parts, request service from the retailer where you purchased the tool or the nearest NITTO service member store.

Repair requires special knowledge and skills. If repair is performed at a place other than a specialty store, the tool may not demonstrate its full performance or it could lead to an accident or injury.

Request repair with the failed status kept intact. When requesting a repair, do not throw away damaged parts.

Do not change the condition of the tool as it could provide important information for investigating the cause of the failure.

- **Use genuine parts.**

If inappropriate parts are used, it could cause accident or injury.

Genuine parts are listed in the instruction manual or brochure. Inquire at the retailer where you purchased the tool or the nearest NITTO service member store.

- **Do not remove the labels or nameplates on the tools.**

If a label or nameplate is damaged or peeling, contact the retailer where you purchased the tool or the nearest NITTO service member store to request a replacement label or nameplate.

General Pneumatic Tool Safety Warnings

WARNING

- **Use the tool with proper air pressure.**

If the air pressure is too high, the rotation speed and reciprocation frequency increase and may lead to accelerated damage or wear. It could also cause an unexpected accident.

- **Connect the tool to air piping.**

Some factories may have oxygen, nitrogen, or gas piping as well as air. Before connecting to a pipe, make sure it is the correct piping.

- **Do not start the tool inadvertently.**

Turn off the operation switch before attaching the Connecting Hose to the tool.

- **Always detach the Connecting Hose from the tool before attaching or removing an accessory or maintaining the tool.**

- **Be cautious about exhaust.**

Exhaust from a pneumatic tool contains oil and condensate, etc. Be aware of the exhaust direction so that the exhaust does not directly hit your face or people nearby.

- **Do not allow electricity to contact the tool.**

The pneumatic tool is not insulated against contact by electric sources. Due to the risk of electric shock, do not allow electricity to contact the tool.

CAUTION

- **Handle the tool with care.**

Rough handling could cause accidents or malfunctions. Do not exert an impact on the tool by throwing or dropping it.

- **Handle the Connecting Hose with care.**

Do not carry the tool by holding the Connecting Hose, and do not pull the Connecting Hose to remove it.

Product Specific Safety Rules

WARNING

- **Protect your body from chips.**

Hot chips scatter when working with the tool. To prevent blindness, respiratory disorders, burns or hearing impairment when working, protect your body using protective eyewear, a dust mask, earplugs, gloves (excluding knitted gloves), and long-sleeved work clothes. In addition, do not bring your face close to the tool.

CAUTION

- **Use only genuine Nitto Kohki tips.**

Do not use worn or damaged tips.

1 Application

This is a pneumatic, hand-held tool that uses Indexable Inserts for chamfering mild steel, stainless steel, and aluminum.

2 Checking Inside the Package

When you open the package box, check the contents of the package and also check for any damage that may have occurred during transportation.

If an abnormality is found, request service from the retailer where you purchased the tool or the nearest NITTO service member store.

	Package content and accessories	Quantity	Check		Package content and accessories	Quantity	Check
①	CB-01 (main unit)	1		⑤	Bushing R1/4×NPT1/4	1	
②	Spanner T-6F	1		⑥	Instruction Manual (this document)	1	
③	Hex. Socket Screw Key 2	1		⑦	Caution for Use	1	
④	Indexable Insert Set Screw (spare)	2		⑧	EC Declaration of Conformity	1	

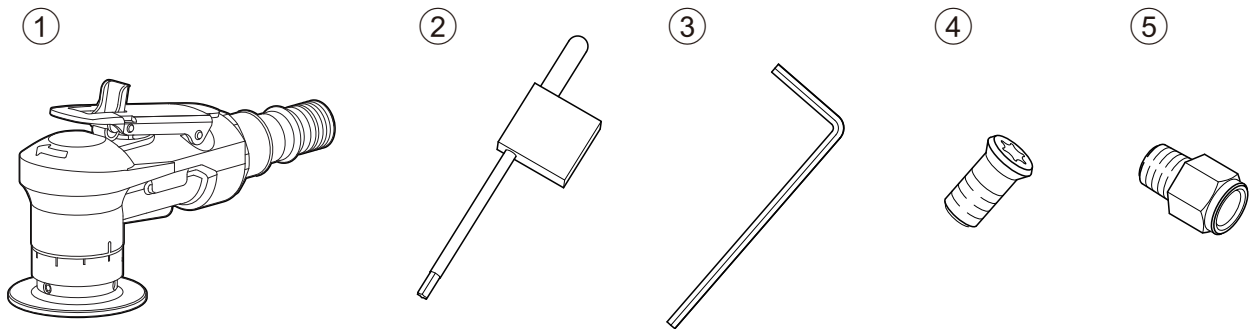

3 Part Names

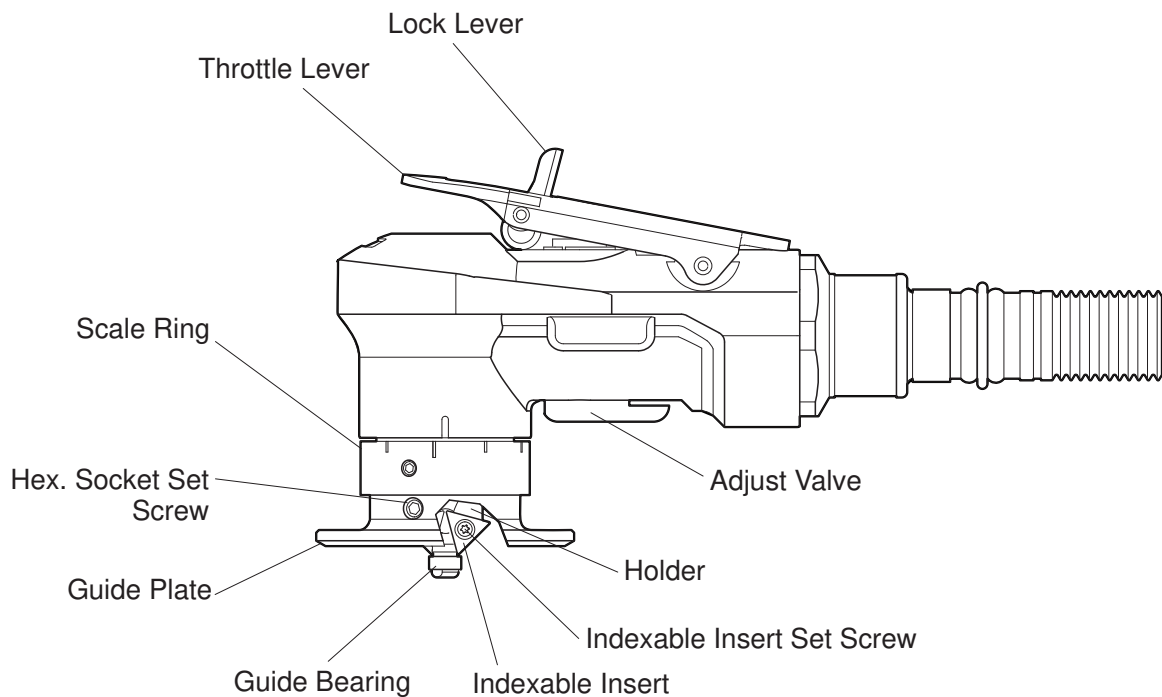

4 Air Supply

⚠ CAUTION

- **Drain the condensate before starting work.**

When drainage enters the tool, the vicinity of the exhaust port freezes, which could cause a loss of power.

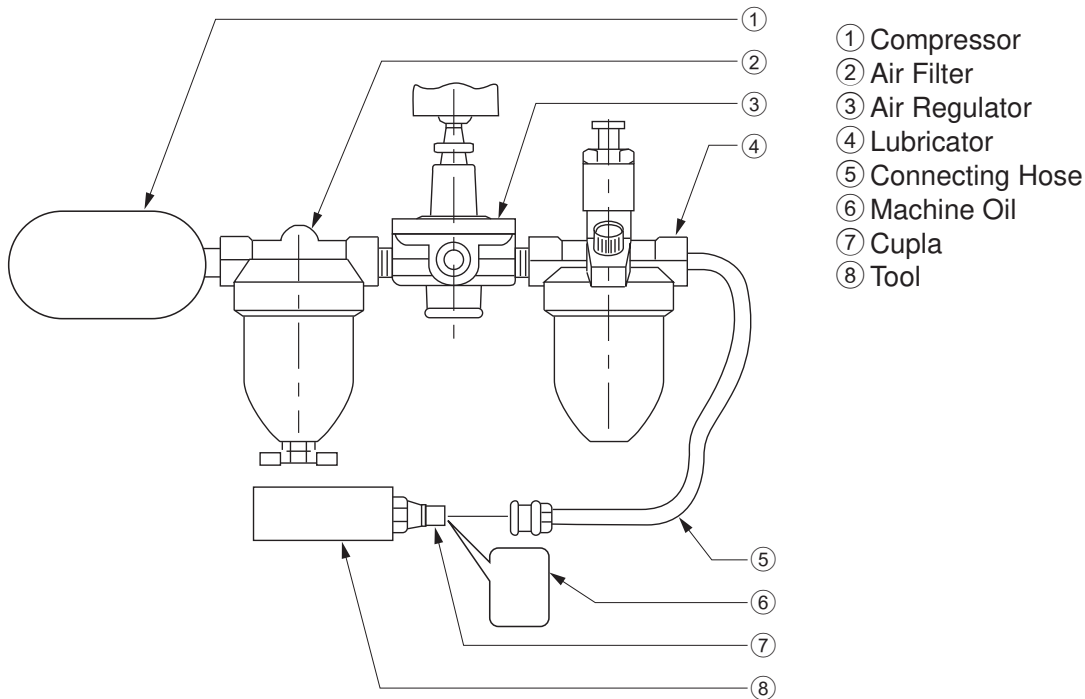

Maximum operating pressure

Use the tool with air pressure at 0.6 MPa. If the pressure is too low, the tool will not perform as intended. If it is too high, it could damage parts of the tool. Use an Air Regulator (③) to adjust the pressure to the appropriate level.

Air line

Use a Connecting Hose (⑤) with an internal diameter of 9.5 mm (3/8") between the Compressor (①) and the tool (⑧). When compressed air exits the Compressor, it cools and the moisture condenses out. Some moisture may condense inside the Connecting Hose and enter the tool, causing a malfunction. Install the Air Filter (②) and Lubricator (④) between the Compressor and the tool.

Machine oil

Install a Lubricator between the Compressor and the tool, and be sure to use machine oil (ISO VG-10). Failure to do so could cause damage to the tool. Also, using a high-viscosity lubricating oil may reduce the tool performance.

Lubrication

Each day before starting work, detach the Connecting Hose and add a few drops of machine oil (ISO VG-10) (⑥) to the tool from the Cupla (⑦).

After lubrication, connect the Connecting Hose and perform idling operation for a few seconds to allow the oil to spread through the entire tool.

5 How to Use

⚠ WARNING

- During work, be sure to wear eye protection, earplugs, a dust mask, and gloves (other than knitted gloves).
- Check that the Throttle Lever is OFF and plug the tool into the Connecting Hose.
- Disconnect the Connecting Hose from the tool when replacing or adjusting the Indexable Inserts or other parts.
- Never touch moving parts while the tool is running.

Dimensions of material that can be chamfered

The following material dimensions can be chamfered.

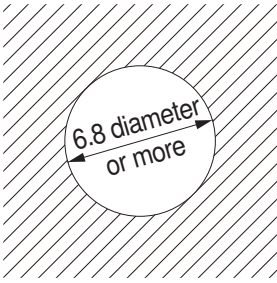
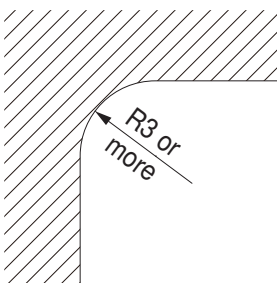
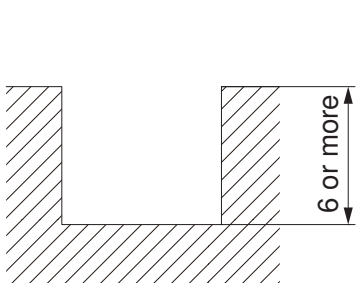
Hole diameter	6.8 mm or more			
Radius	3 mm or more			
Groove depth	6 mm or more			
Plate thickness	1.5 mm or more			

When chamfering a thin plate, adjust the chamfering amount so that a thickness of at least 1 mm is unchamfered. If the unchamfered thickness is 1 mm or less, the plate may get caught in the gap between the Guide Plate and the Guide Bearing.

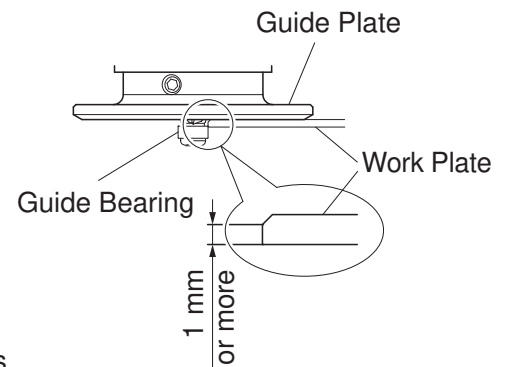
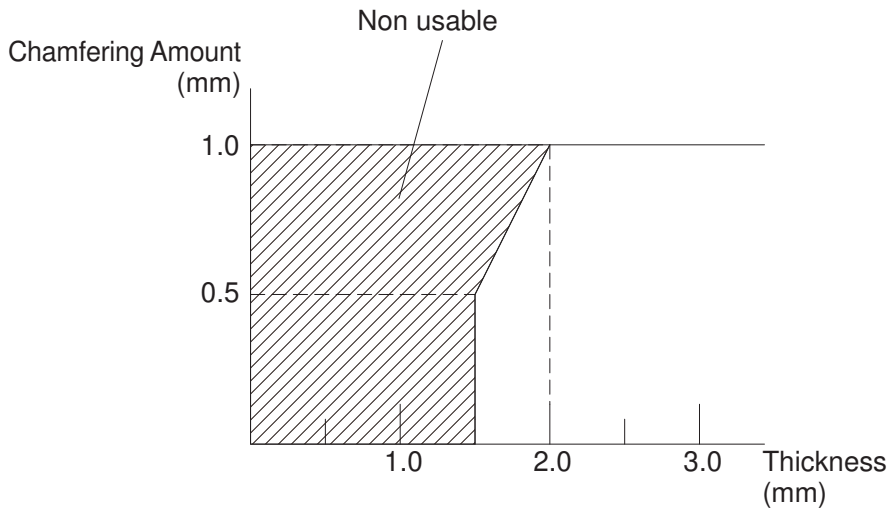

Start and stop

Start

- 1** Check that the Throttle Lever is in the OFF position and insert the Connecting Hose into the tool Cupla
- 2** Hold the tool and press the Throttle Lever (②) while pushing the Lock Lever (①) forward
The tool starts.

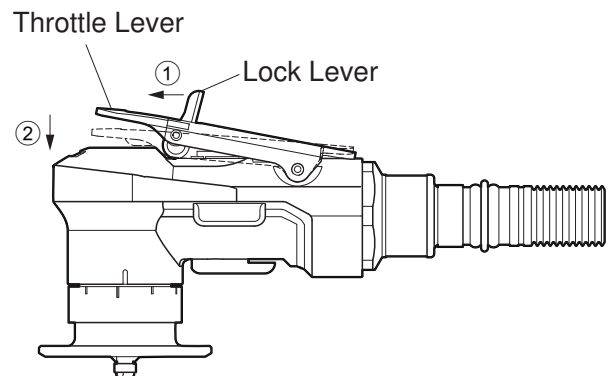

Stop

- 1** Release your hand from the Throttle Lever
The Throttle Lever automatically returns to the OFF position.

Adjusting the chamfering amount

⚠ WARNING

- Disconnect the Connecting Hose from the tool when adjusting the chamfering amount.

⚠ CAUTION

- Make a test cut and check the chamfering amount and finishing condition before using the tool.
- The maximum chamfering amounts are: mild steel C1, stainless steel C0.5, aluminum C1.
- Tighten the 2 Hex. Socket Set Screws attached to the Guide Plate little by little to maintain even balance. Overtightening one screw may allow the Guide Plate to become loose during use.

- 1** Using the Hex. Socket Screw Key 2 (⑤) supplied, loosen the 2 Hex. Socket Set Screws (③) in the Guide Plate (④)
- 2** Turn the Guide Plate (④) to the required chamfering amount
Align the mark on the Scale Ring (②) with the reference line (①) on the tool body.
- 3** Tighten the 2 Hex. Socket Set Screws (③)
- 4** Make a test cut and adjust the chamfering amount

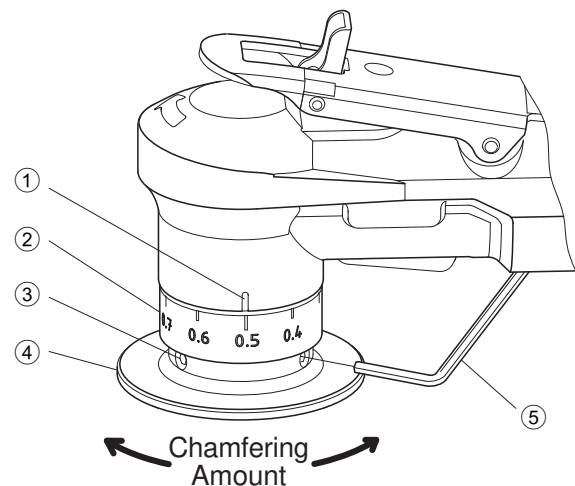

- ① Reference Line
- ② Scale Ring
- ③ Hex. Socket Set Screw
- ④ Guide Plate
- ⑤ Hex. Socket Screw Key 2

⚠ CAUTION

- Do not loosen the Hex. Socket Set Screws in the Scale Ring (②).

Feed rate

⚠ CAUTION

- Using a fast feed rate or imparting shocks during machining may break the Indexable Inserts or damage the tool body.

Use the appropriate feed rate for cutting according to the guide below.

C0.5	10 cm/sec
C1	5 cm/sec

Using an incorrect feed rate may result in burning of the machined surface. Replace the Indexable Inserts if the chips are burned even when the feed rate is appropriate.

Replacing the Indexable Inserts

⚠ WARNING

- Disconnect the Connecting Hose from the tool when replacing the Indexable Inserts.
- Take due care, as the Indexable Inserts and Holder are very hot after machining.

⚠ CAUTION

- Replace the two Indexable Inserts together.
Replacing only one Indexable Insert reduces the quality of the machined surface and shortens the service life of the Indexable Inserts.
- Remove any chips adhering to the Indexable Insert supporting section of the Holder and mount the new Indexable Insert.

- 1 Using the Hex. Socket Screw Key (③) supplied, loosen the 2 Hex. Socket Set Screws (①) in the Guide Plate (②)
- 2 Unscrew and remove the Guide Plate (②). Use the Spanner T-6F (⑥) supplied to remove the Indexable Insert Set Screw (⑤)
- 3 Taking care with the direction, mount a new Indexable Insert (④) or rotate the old Indexable Insert to a new face and firmly tighten the Indexable Insert Set Screw (⑤)
Also replace the opposite Indexable Insert.
- 4 Attach the Guide Plate (②), adjust the chamfering amount, and tighten the 2 Hex. Socket Set Screws (①)

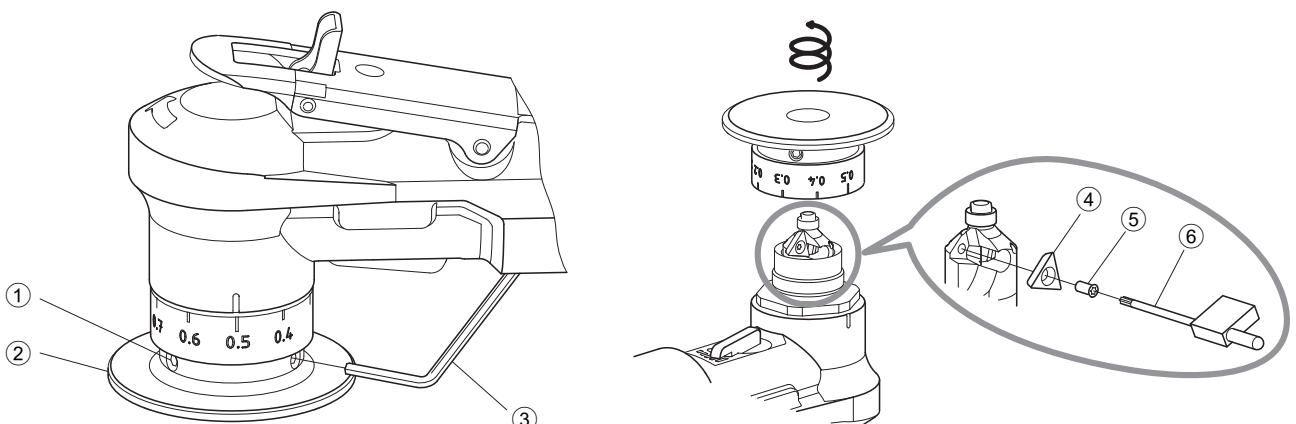

Adjusting the rotation speed

⚠ WARNING

- Never touch moving parts when the tool is running.

Turn the Adjust Valve to change the air flow rate and adjust the rotation speed.
If necessary, adjust the rotation speed.

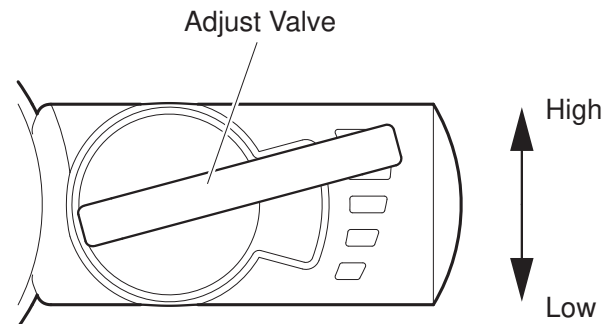

Chamfering

⚠ CAUTION

- **Turn ON the Throttle Lever and press the rotating Holder against the work plate.**
Setting the Throttle Lever in the ON position while the Holder is in contact with the work plate or suddenly pushing it against the work plate may damage the Indexable Inserts.
- **To start machining at a corner, first remove the corner with a grinder before starting chamfering.**
Starting machining at a corner applies a large shock to the Indexable Inserts, which may break the Indexable Inserts or damage the tool body, and could lead to injury.

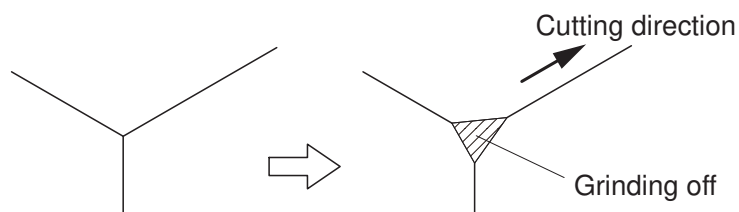

- 1 Turn ON the Throttle Lever to rotate the Holder**
- 2 Hold the tool body firmly. Place the Guide Plate on the top surface and gently press the Indexable Inserts in contact**
- 3 Perform chamfering by pushing the tool in the direction of the arrow so that the guide bearing moves along the side face**

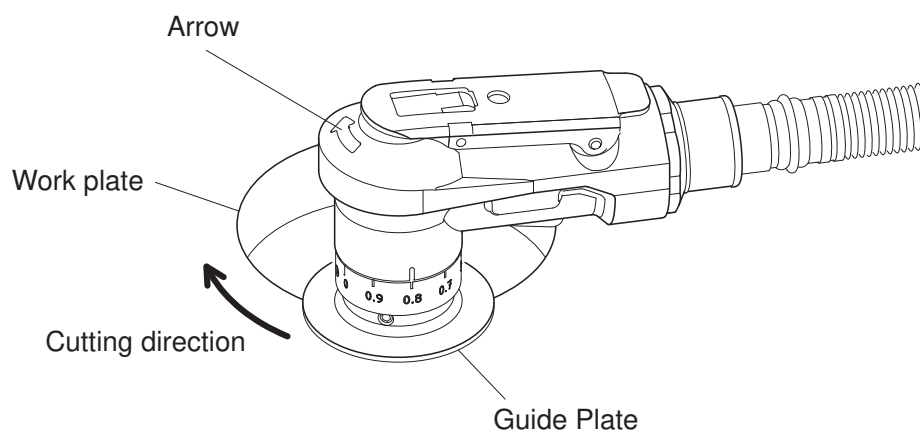

Replacing the Guide Bearing

⚠ CAUTION

- Hitting the Guide Bearing against steel or applying excessive force to it may result in damage to the Guide Bearing.
- Dust or cutting chips entering the Guide Bearing may reduce the bearing life.
Use an air blow gun to keep it clean.

1 Remove the Guide Plate and Indexable Inserts

Refer to “Replacing the Indexable Inserts” (p.9).

2 Insert the Hex. Socket Screw Key 2 supplied or a 2 mm dia. needle (2) into the hole in the Holder (5) to secure it

3 Turn the 4 mm Spanner Wrench (1) counterclockwise to remove the Bearing Set Screw (3)

4 Mount the new Guide Bearing (4) with the Bearing Set Screw (3) and tighten the screw by turning it clockwise with the 4 mm Spanner Wrench (1)

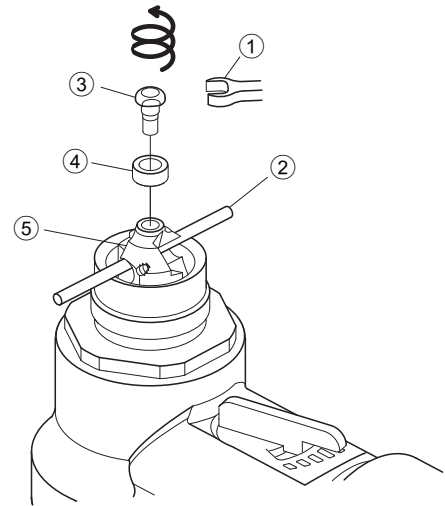

- ① 4 mm Spanner Wrench
- ② Hex. Socket Screw Key 2 or 2 mm dia. Needle
- ③ Bearing Set Screw
- ④ Guide Bearing
- ⑤ Holder

6 Maintenance and Inspection

Storing the tool

Store the tool according to the following warnings and cautions.

⚠ WARNING

- When the tool is not in use, store out of the reach of children.

⚠ CAUTION

- When the tool is not in use, store in a place with low humidity.
- After completing work, add machine oil (ISO VG-10) through the Cupla of the tool and operate the tool a little before storing.
If the tool is left as is after use, moisture in the air remaining inside the tool body may cause corrosion.

Maintaining the tool

Indexable Insert supporting section of the Holder may sag after a long period of use. A large amount of sagging of the tip support surfaces allows the Indexable Inserts to become easily damaged. If this occurs, replace the Holder.

Indexable Insert supporting section

Holder

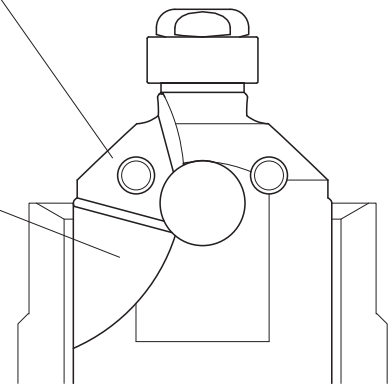

Maintaining the Guide Plate

Cutting chips entering the threads of the Guide Plate and tool body may stop the Guide Plate rotating so that it cannot be correctly tightened.

In the cases below, remove the Guide Plate and clean away the chips with an air blow gun.

- When work is complete
- When replacing the Indexable Inserts
- When adjusting the chamfering amount

Air blow

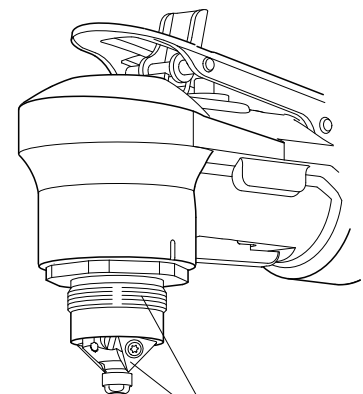
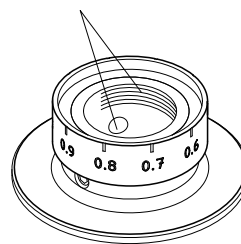

Air blow

Ordering parts

To order parts, contact the retailer where you purchased the tool and specify the part numbers, part names and quantity.

Disposal

- Separate the tool, accessories, and packing materials for environmentally-friendly recycling.
- When disposing of the tool, follow the rules of each municipality.

7 Separately-sold Products

Various optional parts are available. Select them to suit the application. To purchase these items, contact the retailer where you purchased the tool.

Part no.	Product name
TB09097	Indexable Insert 8.4 Ass'y (10 pcs.)
TB09338	Indexable Insert 8.4 SUS Ass'y (10 pcs.)
TB10407	Indexable Insert 8.4 AL Ass'y (4 pcs.)
TB09140	Guide Plate 78 Ass'y Set
TB09143	Plate Ass'y for Straight edge use

WARNING

- **Disconnect the Connecting Hose from the tool when installing or replacing the optional parts.**

Exploded View/Parts List

CB-01 Exploded View/Parts List

⚠ CAUTION

● **Users should never disassemble the tool.**

This illustration is for reference only.

For repair or replacement of the tool, request service from the retailer where you purchased the tool or the nearest NITTO service member store.

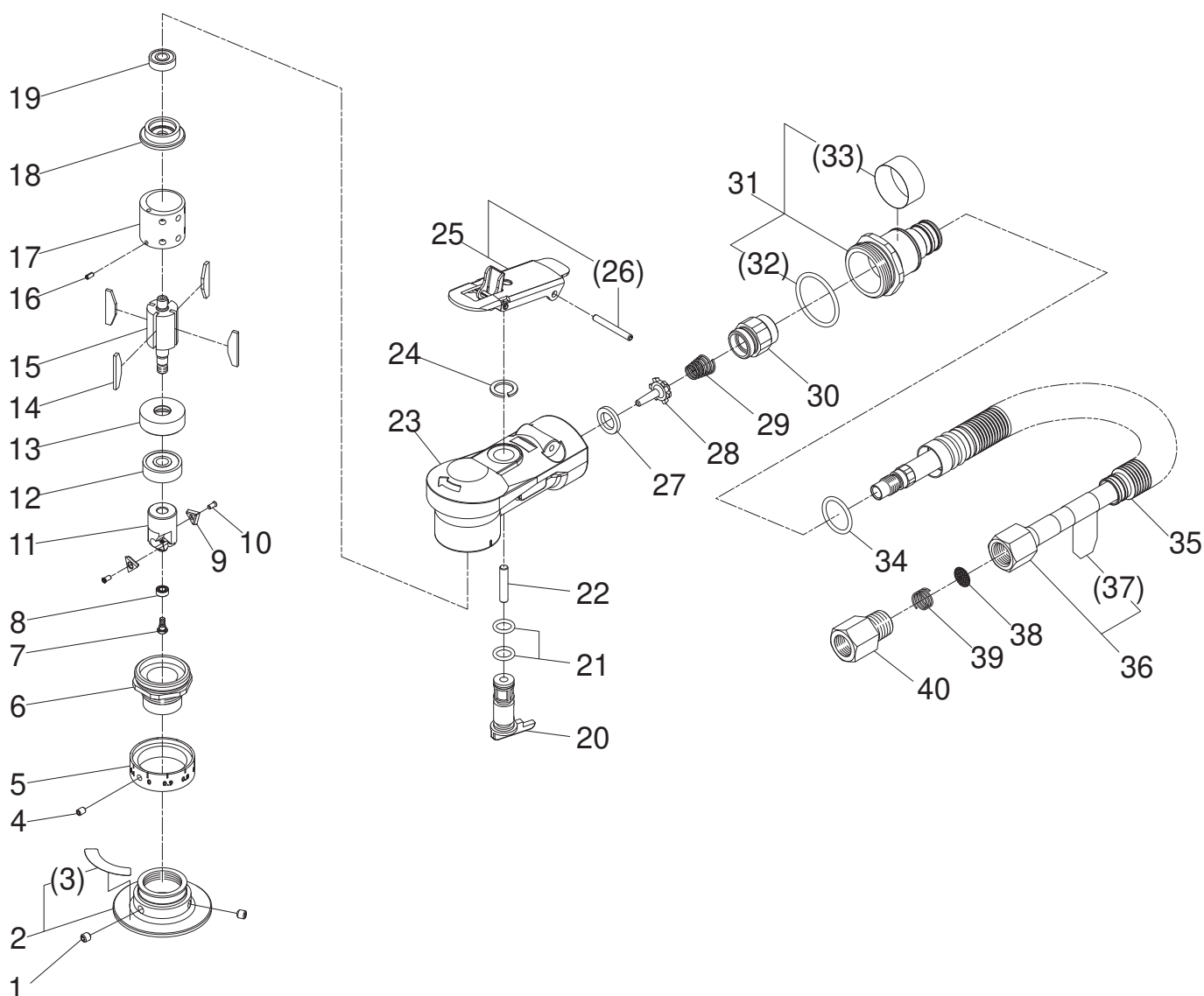

*1 indicates a consumable item, *2 indicates a commercial item. Parts in parentheses () are constituent parts of the assembly above.

No.	Part no.	Part name	Quantity
1	TP15643	Hex. Socket Set Screw 4×4	2
2	TB09245	Guide Plate Sub Ass'y	1 set
(3)	(TQ13684)	Label Caution	1
4	TQ11146	Hex. Socket Set Screw 3×4	1
5	TQ15534	Scale Ring	1
6	TQ13347	Lock Screw	1
7	TQ13354	Bearing Set Screw	1

No.	Part no.	Part name	Quantity	
*1 *2	8	TQ13355	Ball Bearing 630ZZ	1
*1	9	TQ13368	Indexable Insert	2
	10	TQ13369	Indexable Insert Set Screw	2
	11	TQ13350	Holder	1
*1 *2	12	TP15408	Ball Bearing 626ZZ	1
	13	TQ13345	End Plate B	1
*1	14	TB09122	Blade Ass'y (4pcs.)	1 set
	15	TQ13342	Rotor	1
	16	TP04225	Spring Pin 2×4	1
	17	TQ13346	Cylinder	1
	18	TQ13344	End Plate A	1
*1 *2	19	TQ07225	Ball Bearing 695ZZ	1
	20	TQ13351	Adjust Valve	1
	21	TP12003	O-ring KS-5	2
	22	TQ13454	Parallel Pin B 4×20	1
	23	TQ13381	Housing	1
	24	TQ13374	Retaining Ring ISTW-10	1
	25	TB09088	Lever Ass'y	1 set
	(26)	(TQ13428)	Spring Pin 3×25	1
	27	TQ04671	Seal Sheet 9×13.9×2	1
	28	TQ04664	Valve	1
	29	TQ04665	Conical Spring 0.8×6.4×11.6×21.8	1
	30	TQ13352	Connection	1
	31	TB09246	Hose Holder Ass'y	1 set
	(32)	(TP08812)	O-ring S-25	1
	(33)	(TQ13683)	Label Model	1
	34	CP28152	O-ring JASO-1012	1
	35	TQ04367	Exhaust Hose	1
	36	TB08130	Air Hose J Ass'y	1 set
	(37)	(TQ11519)	Label Lubrication	1
	38	TQ13625	Filter	1
	39	TQ13621	Filter Spring	1
	40	TQ04709	Bushing R1/4×Rc1/4	1

Accessories

No.	Part no.	Part name	Quantity
	TQ13369	Indexable Insert Set Screw	2
	TQ13376	Spanner T-6F	1
	TP13892	Hex. Socket Screw Key 2	1
	TP02236	Bushing R1/4×NPT1/4	1
	TQ13632	Instruction Manual	1